

PROGRAMMABLE f/I - f/f CONVERTER



- Pulse calculator
- Frequency generator
- Galvanic isolation, optional ATEX Ex
- Analogue current and voltage output
- PNP / NPN output, optional relays
- Universal supply



Supply voltage: 24...250 VDC
 24...230 VAC

INPUT RANGE:

Frequency: 0...20000 Hz
Sensor types: NAMUR, tacho,
 NPN, PNP, TTL, SO

OUTPUT RANGE:

Current and voltage output: 0...20 mA / 0...10 V
Relay outputs: 0...20 Hz
NPN and PNP output as f/f: 0...1000 Hz
NPN and PNP output as generator: 0...20000 Hz

In general:

By way of a standard PC and the Loop Link programming kit, the PRecon 5223 f/I - f/f converter is configured acc. to the requested function.

Alternatively, the 5223 may be delivered fully-configured acc. to your specifications, see the Options Index on the next page.

Typical pulse sources are flow meters, tacho generators, mechanical switches, or inductive proximity sensors.

Applications:

The f/I function performs frequency to current and voltage conversion.

The output can be programmed to show period, meaning that the input frequency can be converted to a linear time signal.

The digital outputs are used as e.g. a frequency watch for speed control or as a window comparator having one status between 2 limits and the opposite status outside these limits.

The f/f function can be used for pulse division or multiplication and as a buffer collecting fast pulse trains. The input pulses are calculated, counted in a buffer, and sent to the output as a pulse train with the programmed pulse width.

A scale factor may be entered in all functions. Using both digital inputs, pulse addition or subtraction are possible. This function permits readout of the actual consumption at measurement of e.g. liquid flows forward and reverse.

The frequency generator function is used as e.g. a time base or clock generator.

The 2-phase encoder, or directional f/I conversion, converts 2 90°-phased digital inputs to an analogue speed signal with digital output for directional indication.

ATEX units have input for mechanical contact and NAMUR inductive proximity sensor.

Technical characteristics:

Inputs:

2 programmable inputs for standard pulse generator connection.

Normally, the auxiliary supply and trigger level follow the sensor type, but these can be programmed to other values.

At contact input, the 50 Hz filter should be applied.

The PRecon 5223 is protected against polarity reversal on input and supply.

Analogue output:

The current and voltage signals are galvanically separated from the supply and the inputs.

The analogue current and voltage output can be scaled acc. to your choice in relation to the digital input. Max. zero offset is 50% of selected measurement range. Programmable reaction time.

Short-circuit-protected output.

When both current and voltage signals are used simultaneously, the mA loop to ground must pass through the internal shunt.

Standard voltage output (pin 12) is obtained by leading the current signal (pin 13) through an internal shunt resistor (pin 12). At voltage signals in the ranges 0...1 VDC, a 50 Ω shunt (JP1) is applied; in the ranges 0...10 VDC, a 500 Ω shunt (JP2) is applied.

Digital output(s):

The action on the outputs can be inverted, and the hysteresis can be set acc. to your specifications.

At power-up, shifts on the outputs can be delayed for up to 999 s.

NPN and PNP outputs for external relay, electromechanical counter, PLC input, or equivalent load.

The outputs are current-limited by way of PTC resistors.

Relay outputs:

The PRecon 5223 can be delivered with 2 relay outputs that are programmed individually.

Status indication:

The 5223 is equipped with 5 front LEDs.

f1 and f2 in: Indicate an active input (non-active at NPN input)

Dig.out.1 and 2: Indicate active output
Error: Programmable by use of PReset to indicate sensor errors

Options index 5223:

*1: f/I converter

*2: f/f converter

*3: Frequency generator

*4: 2-phase encoder

Digital input:

*1 Unit: Frequency / Period
0% ____ Hz/s 100% ____ Hz/s

*4 Unit: Frequency / Period
Forward 0% ____ Hz/s 100% ____ Hz/s
Reverse 0% ____ Hz/s 100% ____ Hz/s

*1,2,4 A Input type: Tacho / TTL / NPN / PNP / S0 / NAMUR
Special Current / Special Voltage
Trig level ____ mA/V Spec. sensor supply ____ V

*1,2,4 Input filter:
Disable / 50 Hz Lowpass

*2 B Input type: Tacho / TTL / NPN / PNP / S0 / NAMUR
Special Current / Special Voltage
Trig level ____ mA/V Spec. sensor supply ____ V

Analogue output:

*1 Unit: Current / Voltage
Fixed output ____ mA/V / Specify 0% ____ mA/V 100% ____ mA/V

*4 Unit: Fixed output / Forward / Reverse
____ mA/V 0% ____ mA/V 100% ____ mA/V / 0% ____ mA/V 100% ____ mA/V

*1,4 Response time:
____ s

*1,4 Sensor error (NAMUR):
Off / Hold / Specify error value ____ mA

Digital output:

*1,4 Digital output 1: Off / Activate for incr. freq. / Activate for decr. freq.
Setpoint ____ Hz/s Hysteresis ____ Hz/s Power on delay ____ s

*4 Digital output 1:
Forward / Reverse

*3 Frequency:
____ Hz

*2 Digital output 1 Action: Addition / Subtraction / Multiplication A / Multiplication B / Division A / Division B
P1: _____ P2: _____ Pulse time ____ s

Addition:	OUT 1 = P1*InA+P2*InB		
Subtraction A-B:	OUT 1 = P1*InA-P2*InB	Subtraction B-A:	OUT 1 = P2*InB-P1*InA
Multiplication A:	OUT 1 = P1*InA	Multiplication B:	OUT 1 = P2*InB
Division A:	OUT 1 = P1/InA	Division B:	OUT 1 = P2/InB

*1,4 Digital output 2: Off / Activate for incr. freq. / Activate for decr. freq.
Setpoint ____ Hz/s Hysteresis ____ Hz/s
/ Window
High limit ____ Hz/s Low limit ____ Hz/s

*4 Function:
Forward / Reverse

*1,2,4 Digital 1 and 2 output function:
NPN or relay N.C. / PNP or relay N.O.

*1,4 Sensor error action dig. out 1 & 2 (NAMUR):
Off / Close / Open / Hold

*2 Sensor error action dig. out 2:
Off / Close / Open / Hold

*1,2,4 Error LED:
Disable / Sensor error (NAMUR) / Beyond input limits / Sensor error & Beyond input limits (NAMUR)

Order: 5223

Type	Version	Output
5223	Standard : A	Analogue + NPN / PNP : 1
	ATEX Ex : B	Analogue + Relay output : 2

Block diagram, 5223A:

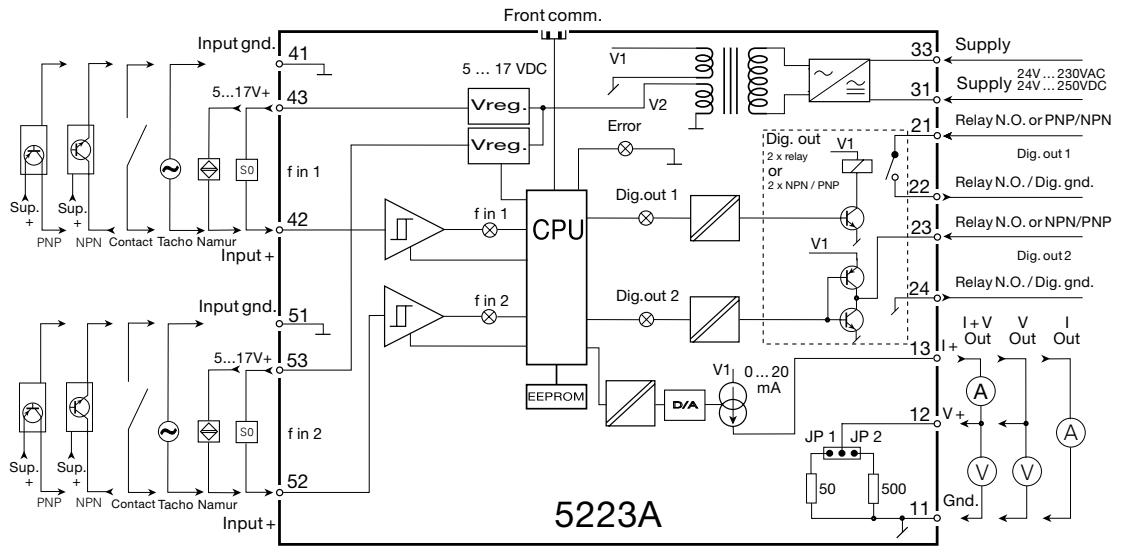

Block diagram, 5223B:

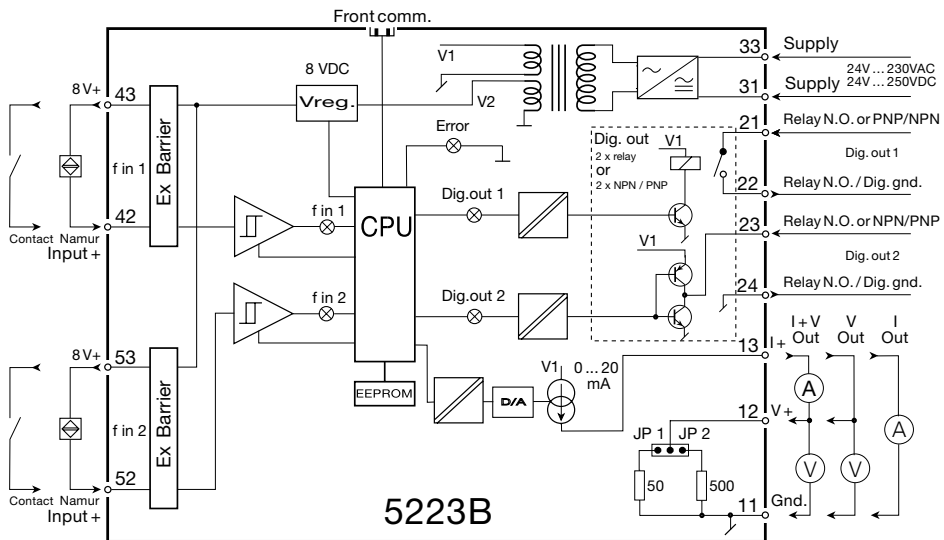

Front layout:

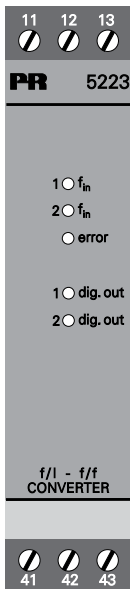

5223 connection to Loop Link:

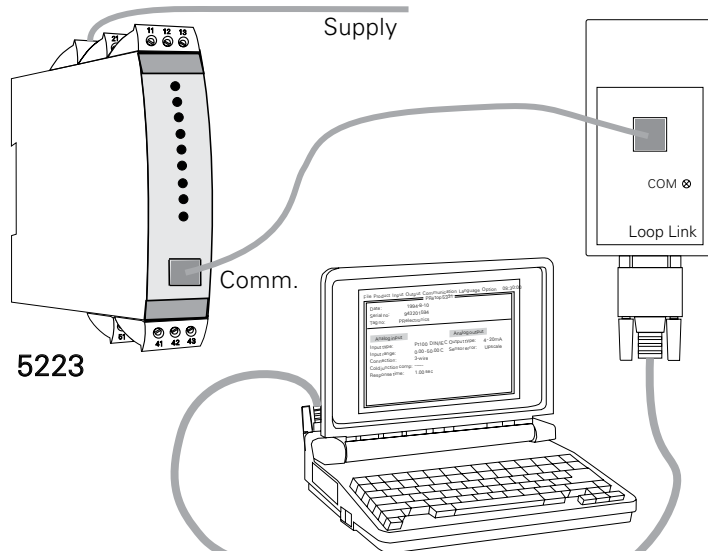

Electrical specifications - type 5223:

Specifications range:

-20°C to +60°C

Common specifications:

Supply voltage.....	19.2...300 VDC or 21.6... 253 VAC
Frequency.....	50...60 Hz
Fuse.....	400 mA SB / 250 VAC
Internal consumption.....	3 W
Max. consumption.....	3.5 W
Isolation, test / operation.....	3.75 kVAC / 250 VAC
Power-up delay.....	0...999 s
Warm-up time.....	1 min.
Communications interface.....	Loop Link
Signal / noise ratio.....	Min. 60 dB
Response time, analogue.....	< 60 ms + period
Response time, digital output.....	< 50 ms + period
Calibration temperature.....	20...28°C
Temperature coefficient.....	< ±0.01% of span / °C
Linearity error.....	< ±0.1% of span
Effect of supply voltage change.....	< 0.005% of span / VDC

Auxiliary voltages:

Namur supply.....	8.3 VDC ±0.5 VDC / 8 mA
Namur supply EEx.....	8.9 VDC ±0.5 VDC / 8 mA
S0 supply.....	17 VDC / 20 mA
NPN / PNP supply.....	17 VDC / 20 mA
Special supply (programmable).....	5...17 VDC / 20 mA

EMC immunity influence < ±0.5%

Max. wire size.....	1 x 2.5 mm ² stranded wire
Screw terminal torsion.....	0.5 Nm
Air humidity.....	< 95% RH (non cond.)
Dimensions (HxWxD).....	109 x 23.5 x 130 mm
DIN rail type.....	DIN 46277
Protection degree.....	IP20
Weight.....	240 g

Input:

General:

Measurement range.....	0...20 kHz
Min. measurement range.....	0.001 Hz
Max. offset.....	90% of selected max. frequency
Min. pulse width (without filter).....	25 µs
Min. period (without filter).....	50 µs
Max. frequency (without filter).....	20 kHz
Min. pulse width (with filter).....	10 ms
Min. period (with filter).....	20 ms
Max. frequency (with filter).....	50 Hz
Programmable trig level.....	0.025...6.5 V (nom.) 1...8 mA

NAMUR input acc. to DIN 19234:

Trig-level LOW.....	≤ 1.2 mA
Trig-level HIGH.....	≥ 2.1 mA
Input impedance.....	1000 Ω

Sensor error detection (only for NAMUR):

Breakage.....	≤ 0.1 mA
Short-circuit.....	≥ 7.0 mA
Response time.....	≥ 400 ms

Tacho input:

Trig-level LOW.....	≤ -40 mV
Trig-level HIGH.....	≥ 40 mV
Input impedance.....	≥ 100 kΩ
Max. input voltage.....	80 VAC pp

NPN / PNP input:

Trig-level LOW.....	≤ 4.0 V
Trig-level HIGH.....	≥ 7.0 V
Input impedance, standard.....	3.48 kΩ
Input impedance, special version.....	3.48...12 kΩ

2-phase encoder:

Min. pulse width (without filter).....	1 ms
Min. period (without filter).....	2 ms
Max. frequency (without filter).....	500 Hz

TTL input:

Trig-level LOW.....	≤ 0.8 VDC
Trig-level HIGH.....	≥ 2.0 VDC
Input impedance.....	≥ 100 kΩ

S0 input acc. to DIN 43 864:

Trig-level LOW.....	≤ 2.2 mA
Trig-level HIGH.....	≥ 9.0 mA
Input impedance.....	800 Ω

Analogue output:

Current output:

Signal range.....	0...20 mA
Min. signal range.....	5 mA
Max. offset.....	50% of selec. max. value
Signal dynamics.....	16 bit
Updating time.....	20 ms
Load (max.).....	20 mA / 600 Ω / 12 VDC
Load stability.....	< ±0.01% of span / 100 Ω
Current limit.....	≤ 23 mA

Voltage output through internal shunt:

Signal range.....	0...10 VDC
Min. signal span.....	250 mV
Max. offset.....	50% of selec. max. value
Load (min.).....	500 kΩ

Active outputs (NPN / PNP):

I _{max} . source.....	10 mA
I _{max} . sink.....	130 mA
V _{max}	28 VDC

f/f converter output:

Signal range.....	0...1000 Hz
Min. pulse width.....	500 µs
Max. pulse width.....	999 ms
Max. duty cycle.....	50%

Frequency generator:

Min. period.....	50 µs
Max. frequency.....	20 kHz
Duty cycle.....	50%

Relay output:

Frequency max.....	20 Hz
V _{max}	250 VRMS
I _{max}	2 A / AC
Max. AC power.....	500 VA
Max. AC power Ex version 5223B.....	100 VA
Max. load at 24 VDC.....	1 A

EEx / I.S. approval:

KEMA 04ATEX1001.....	⊕ II (1) GD [EEx ia] IIC
Applicable for zone.....	0, 1, 2, 20, 21 and 22

Ex / I.S. data for 5223B:

Terminal 31, 33.....	U _m : 250 V
Terminal 42, 43 and 52, 53.....	U _o : 10.6 VDC
U _o	U _o : 10.6 VDC
I _o	I _o : 13.8 mA
P _o	P _o : 38 mW
L _o	L _o : 160 mH
C _o	C _o : 1.9 µF

GOST R approval:

VNIIM & VNIIFTRI, Cert. no. www.prelectronics.com

Observed authority requirements: Standard:

EMC 2004/108/EC.....	EN 61326-1
LVD 2006/95/EC.....	EN 61010-1
PELV/SELV.....	IEC 364-4-41 and EN 60742
ATEX 94/9/EC.....	EN 50014 and EN 50020 EN 50284

Of span = Of the presently selected range