

*Explosion proof solenoid valve for a confident control in rough working environments*

### Features

- ▶ Rugged aluminum die-cast housing
- ▶ Convertible from 5/2 way to 3/2 way
- ▶ Rotatable valve head for optimal mounting
- ▶ Direct NAMUR mounting or screw mounting

### Specifications

Model	ESV-S
Operating Air Pressure	1.5 - 10 kgf/cm <sup>2</sup>
Air Supply (Max.)	15 kgf/cm <sup>2</sup>
Operating Voltage : Current	AC 110V : 55 mA AC 220V : 17 mA DC 24V : 138 mA
Voltage Tolerance	±10%
Frequency	50Hz / 60Hz
Explosion Proof Class	Exd IIC T6 (KOSHA Cert. No. 2008-1052-Q1)
Operating Ambient Temperature	-20°C - +60°C
Flow Capacity (Cv)	0.9
Mounting Configuration	NAMUR or screw interface
Pneumatic Connections	Rc 1/4 or NPT 1/4
Electrical Connection	G 1/2 or NPT 1/2
Coil Insulation Grade	Class F
Duty Cycle	100%
Weight	0.9 kg

### Mounting

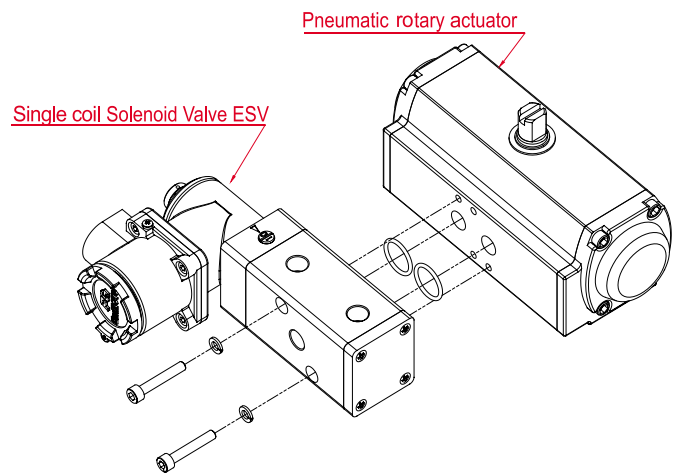

### Rotatable Valve Head

The ESV valve head can be rotated by 90° to the right or to the left for an optimal mounting as shown below

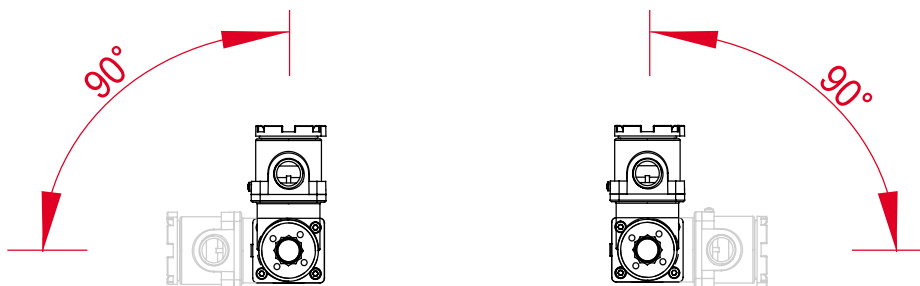

# ESV-S (Single Coil)

# Solenoid Valve

## How to Order

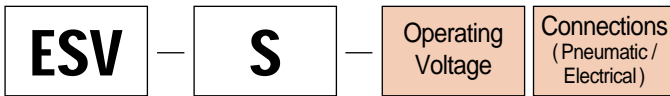

Description	Code
<b>Operating Voltage:</b>	A220 : AC 220V A110 : AC 110V D24 : DC 24V
<b>Connections:</b> (pneumatic - electrical)	P : Rc 1/4 - G 1/2 N : NPT 1/4 - NPT 1/2

Ex) ESV-S-D24P (Single Coil, 24VDC, Rc 1/4 - G 1/2)

## Symbol of Operation

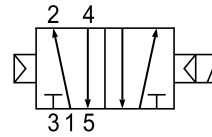

## Dimensions

### Single Coil Type

