



Reliable valve control device guaranteeing optimum span and zero settings by smart auto-calibration function

Features

- ▶ Auto-Calibration for optimum zero and span setting
- ▶ Simple and easy to set
- ▶ Precise control performance and high dynamic response
- ▶ Pressure regulator built in to eliminate variations in supply air pressure
- ▶ Low air consumption due to piezo electric microvalve
- ▶ Input / output signal isolated
- ▶ Automatic detection for DA(direct acting) or RA(reverse acting)
- ▶ Single and double acting available
- ▶ No hunting on the small actuators
- ▶ 1/2 split range available
- ▶ High resistance against shock and vibration

Options

- ▶ Position transmitter (4...20mA output signal)
- ▶ 2 x alarm limit (open, close)
- ▶ Explosion proof type (Exd IIB T6, Exia IIC T6)

Specifications

Input Signal	4 - 20 mA DC
Voltage Supply Min. /Max.	8.5V DC / 30V DC (425 ohm)
Power Consumption	30.8 mW @ 4 mA / 170 mW @ 20 mA
Characteristic	Linear (Note)
Stroke	5 - 65 mm (max. up to 150 mm)
Air Supply Pressure	1.5 - 7.0 bar (20 - 100 psi) Pressurized air or allowed gas, free of water, oil, and dust
Air Capacity	6.6 kg/h = 5.4 m ³ /h = 3 scfm @ supply air of 1.4bar (20psi)
Air Consumption	< 0.04 kg/h
Output Pressure Range	0 - 100% of supply air pressure
Linearity	Within ± 0.5 %
Hysteresis	Within 0.2 %
Sensitivity	Within ± 0.2 %
Operating Temperature	-20 - +80 °C
Pneumatic Connections	Rc 1/4 or 1/4 NPT
Electrical Connections	G 1/2 or 1/2 NPT
Protection Class	IP66, intrinsic safety (Exia) or flameproof (Exd)
Body Material	Aluminum die-cast
Weight	2.5 kg

Note : Equal percentage or Quick-open option is available.
Please contact for more details

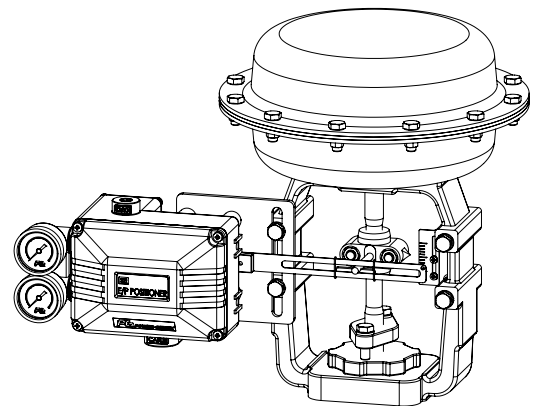

Mounting

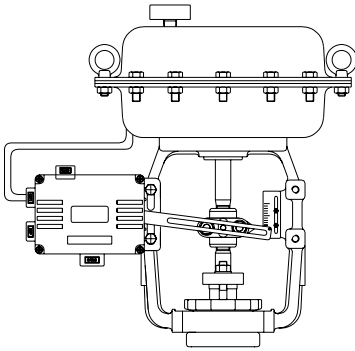

General Mounting to Linear Actuator

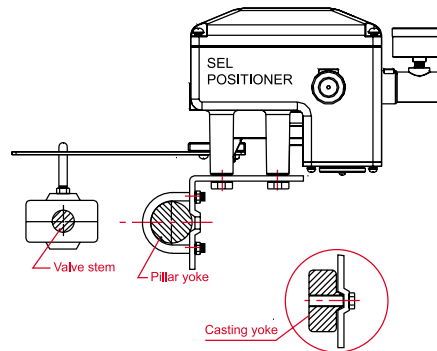

Mounting to Linear Actuator to IEC 534

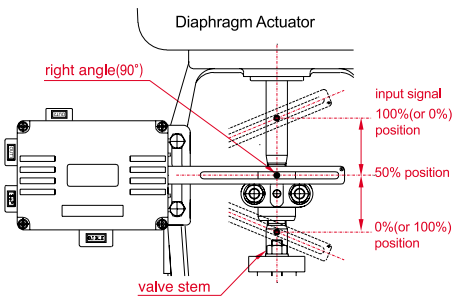

Feedback Lever Installation

Air Connections

Direct Acting (DA)

As the input signal increases,
Valve stem moves downwards
Actuator : DA
Switch position : DA

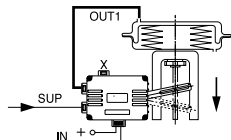

OUT2 must be plugged

As the input signal increases,
Valve stem moves downwards
Actuator : DA
Switch position : DA

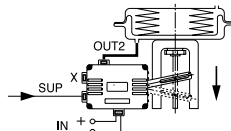

OUT1 must be plugged

As the input signal increases,
Valve stem moves downwards
Switch position : DA

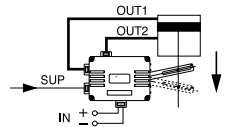

Reverse Acting (RA)

As the input signal increases,
Valve stem moves upwards
Actuator : RA
Switch position : RA

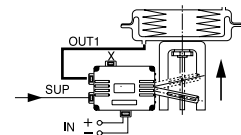

OUT2 must be plugged

As the input signal increases,
Valve stem moves upwards
Actuator : RA
Switch position : RA

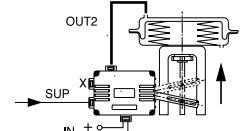

OUT1 must be plugged

As the input signal increases,
Valve stem moves upwards
Switch position : RA

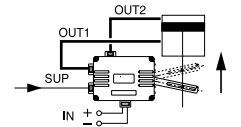

Electrical Connections

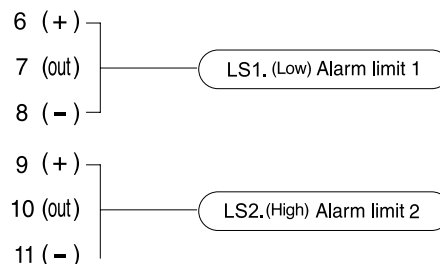
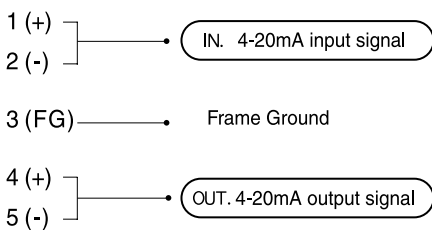

Board View

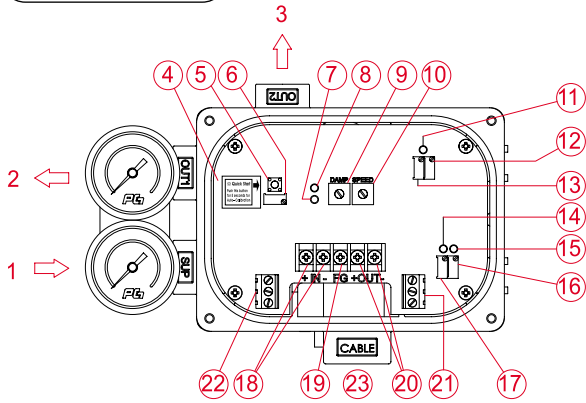

① Supply air	⑬ Feedback zero
② OUT 1	⑭ Limit switch lamp 2
③ OUT 2	⑮ Limit switch lamp 2
④ Board cover	⑯ Limit switch 2 adjusting screw
⑤ Auto-setting button	⑰ Limit switch 1 adjusting screw
⑥ Span adjusting screw	⑱ Input signal +, -
⑦ DA lamp	⑲ Frame ground
⑧ RA lamp	⑳ Output signal +, -
⑨ Damping screw	㉑ Limit switch 2 terminal
⑩ Speed adjusting screw	㉒ Limit switch 1 terminal
⑪ Feedback lamp	㉓ Electrical connections
⑫ Feedback span	

Auto-Calibration

Push Auto-Setting button ⑤ for 5 seconds for auto-calibration. Generally it will take 2 - 3 minutes until the process is finished but it can take more time according to the actuator volume.

Measuring 4-20mA Output Signal

1) Specifications

Output Signal	4 - 20 mA, 2 - wire
Power Supply Rating	15 - 30V DC
Recommended Power Supply	24V DC
Operating Temperature	-20 - +70 °C
Input Impedance	0 - 430 Ω
Characteristic	Linear
Linearity	± 1.0 % F.S.
Hysteresis	0.5 % F.S.
Repeatability	± 0.5 % F.S.
Adjustment	Zero and span
Rotary Angle	50...90° (max. 100°)

2) With mA Loop Calibrator

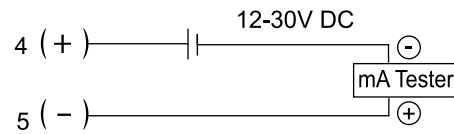

3) With Multi-Meter

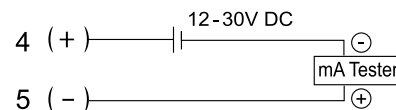

Setting Alarm Limits

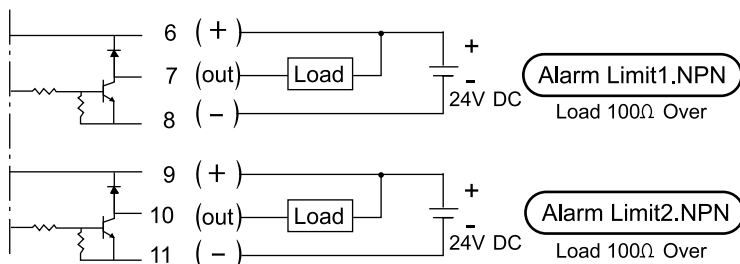

How to Order

SEL —

Protection Class

Feedback Lever

Pressure Gauge (SUP. OUT)

Position Feedback

Connection Threads

Mounting Bracket

Description	Code
Protection Class :	F : Flameproof (Exd IIB T6) I : Intrinsic safety (Ex ia IIC T6) W : Weatherproof to IP66
Feedback Lever :	A : Stroke (5 ~ 65 mm) B : Stroke (10 ~ 85 mm) C : Stroke (up to 150 mm)
Pressure Gauge :	1 : 6 bar (90 psi) 2 : 10 bar (150 psi)

Description	Code
Position Feedback :	N : None (standard) O : Position transmitter (4-20mA output signal) L : 2 x alarm limit M : O + L
Connection Threads: (pneumatic - electrical)	3 : Rc 1/4 - G 1/2 (standard) 4 : NPT 1/4 - NPT 1/2 5 : Rc 1/4 - M20 x 1.5
Mounting Bracket :	N : None L : DIN / IEC 534

Ex) SEL-WA10N (weatherproof, 5 - 65mm stroke, 10 bar pressure gauges, position transmitter)

Dimensions

